



November 16 to 19, 2026

Centre des congrès de Québec

EXHIBITOR'S GUIDE

Exhibitors agree to carefully read the Exhibitor's Guide and to comply with all directives contained therein. The Organizing Committee reserves the right to refuse exhibitors who fail to comply with the guidelines. Some elements of this guide may be revised or modified at any time

EVENT'S LOGISTICS

GENERAL SCHEDULE

	Day	Date	Hours
Short courses and Workshops	Monday	November 16	9:00 a.m. to 5:00 p.m.
Exhibition and Conferences	Tuesday	November 17	9:00 a.m. to 5:00 p.m.
	Wednesday	November 18	9:00 a.m. to 5:00 p.m.
	Thursday	November 19	9:00 a.m. to 12:00 p.m.

INSTALLATION

Day	Date	Hours
Monday	November 16	9:00 a.m to 7:00 p.m.

DISMANTLING

Day	Date	Hours
Thursday	November 19	12:00 p.m. to 4:00 p.m.

No dismantling of booths will be permitted **before noon (12:00 p.m.)** on November 19. Exhibitors who fail to comply with this rule will **lose their reservation priority** for the next Québec Mines + Énergie event. They may be charged a penalty fee of \$10/min. before 12:00 p.m. (12:00 p.m. = \$300 penalty). Conversely, if you have to delay your dismantling **after 1:00 p.m.** please notify us. Dismantling must be **completed by 4:00 p.m.** on Thursday, November 19.

EXIT PROCEDURE AT THE END OF THE EXHIBITION

To view the detailed Move-out Procedure, click on the following link:

<https://www.convention.qc.ca/wp-content/uploads/Moveout-Procedure-ENG-17oct2024.pdf>

ACCESS TO THE EXHIBITION HALL AND LOADING DOCKS - EXHIBITORS ONLY

Day	Date	Hours
Monday	November 16	9:00 a.m. to 7:00 p.m.
Tuesday	November 17	7:00 a.m. to 9:00 a.m.
Wednesday	November 18	7:00 a.m. to 9:00 a.m.
Thursday	November 19	12:00 p.m. to 4:00 p.m.

IMPORTANT

- Please note that delivery and pick-up of materials are prohibited at the entrances to the Centre des congrès de Québec, and must take place at the loading docks only.
- No wheeled carts will be allowed on the aisle carpets.
- The Centre des congrès de Québec will only accept material from **Friday, November 13, 2026**, onwards.
- Pre-event storage fees apply to all exhibitor materials received prior to this date (see **MATERIAL HANDLING AND STORAGE**).

LOCATION

Click on the link to visualize the different accesses to the Centre des congrès de Québec. :

https://www.google.com/maps/d/viewer?mid=1_qQgKqC5JQKy2DTYbtW9u5c0ccNldC9A&femb=1&ll=46.81031700906284%2C-71.21566568177298&z=18

LOADING DOCK USE

Exhibitors are invited to use the loading dock on level 4 to drop off their equipment. It is located at:

855, rue Jean-Jacques-Bertrand
Québec (Québec) G1R 5V3

Trailer trucks **must not exceed** 13' 6" in height and 53' in length.

Parking is **not authorized** at the loading dock or on Promenade Desjardins, even for short periods of time. Only loading and unloading are permitted at the dock, and any failure to comply will result in the vehicle being towed away. The loading dock is designed to accommodate **seven vehicles simultaneously**.

ACCESS FOR HEAVY OR OVERSIZED PARTS

A large door opening onto rue Jean-Jacques-Bertrand is located at the west end of the service corridor on level 4. Its dimensions are 22 feet wide by 15 feet high. If you need to use this door, please contact Ms. Ingrid Metta at: Ingrid.Metta@mrnf.gouv.qc.ca.

PARKING

The Centre des congrès de Québec is located close to numerous underground parking spaces: Place Québec (accessible via rue Saint-Joachim), Complexe Marie-Guyart (Complexe G), Place Haute-Ville (under the Delta Hotel) and, finally, the stationnement D'Youville. All these spaces are linked by underground corridors for added convenience. These parking facilities operate 24 hours a day, Monday to Sunday.

During the week (daytime), we strongly suggest that you consider using sustainable transportation (carpooling, public transit, Parc-O-Bus), due to the high level of activity in the area and to some roadwork. For more information, please visit the Centre des congrès de Québec website at: <https://www.convention.qc.ca/infos-pratiques/#se-rendre>

Parking is prohibited at all times on Promenade Desjardins.

REGULATIONS FOR EXHIBITION SPACE ALLOCATION

Priority will once again be given to exhibitors who participated in the 2025 Edition to choose their location first. A thirty-day period is allotted to confirm booth location renewal and to make the payment.

The Organizing Committee reserves the right to group certain exhibitors by sector of activity. It also reserves the right to refuse an exhibitor if the company's mission, services or products do not fall within the scope of the event.

EXHIBITION BOOTH

All booths are 10' x 10' and include a sober-coloured carpet, a wastebasket, a 15-amps electrical outlet (120 volts), access the to Convention center's Wi-Fi, 1 access to the conference sessions, the replay and exhibition hall, 2 exhibition hall accesses, access to the networking platform, 6 coupons for lunches on Tuesday and Wednesday (1 meal per day per access), 9 coffee and muffin coupons (1 per day per access, valid in the morning only).

AVAILABLE PACKAGES FOR EXHIBITORS

Basic Package: CA\$ 3,120 + taxes	Basic Package with Table and Chairs: CA\$ 3,210 + taxes	Package with White Hard Walls: CA\$ 3,995 + taxes	Package with Hard Walls in Coloured Velcro: CA\$ 4,115 + taxes
<ul style="list-style-type: none"> ■ Dividing curtain walls 	<ul style="list-style-type: none"> ■ 1 table 2'x 6' with black tablecloth ■ 2 chairs ■ Dividing curtain walls 	<ul style="list-style-type: none"> ■ Structure of 5 panels 39'' x 89'' in white PVC ■ 1 white counter 42'' high ■ 2 stools 	<ul style="list-style-type: none"> ■ Structure of 5 panels 39'' x 89'' in coloured Velcro (the choice of colour will depend on the availability) ■ 1 white counter 42'' high ■ 2 stools

STATION AT EDUCATIONAL PAVILION

\$ 1 600 + taxes

*Exclusivity for educational institutions and companies offering specialized training program.

- One counter with sliding doors and shelves
- One wall with a sign identifying your institution
- Two high executive stool
- Carpet on all the surface
- A 15-amps electrical outlet (120 volts)
- Access the to Convention center's Wi-Fi
- Access to the networking platform
- 2 Exhibition hall accesses
- 4 tickets for Tuesday's and Wednesday's lunch (1 meal daily for each access included)
- 6 coffee and muffin coupons (1 per day per access, valid in the morning only).

Please note that participants' names cannot be changed on site.

FURNITURE RENTAL

To rent furniture or customize your exhibition space, we invite you to contact **Tessier Exhibit and Show Services**, the official decorator of the 2026 Edition:

Telephone: 418 524-1888
Fax: 418 524-0006
International: 1 800 760-9488
info@brunotessier.com <https://brunotessier.com/>

On site, last-minute requests can be made at the exhibitor support desk operated by **Tessier Exhibit and Show Services**.

INTERNET AND AUDIOVISUAL EQUIPMENT REQUESTS

Internet connections are managed exclusively by Encore. Wireless Internet (Wi-Fi) is offered free of charge by the Centre des congrès de Québec. For any other connection or audiovisual rental, please communicate by e-mail at: exposants-CCQ-ca@encoreglobal.com.

OVERHEAD MATERIAL

Any material suspended or placed more than 8 ft above the ground (banners, structures, posters, etc.) must be approved by the organizers. Additional charges may apply. For further information, please contact Ms. Ingrid Metta at: Ingrid.Metta@mrnf.gouv.qc.ca or 833 361-0001, extension 605238.

MATERIAL HANDLING AND STORAGE

DURING THE EVENT

Fees for handling and storage of exhibitor's empty crates (boxes) at the Centre des congrès de Québec are included and paid by Québec Mines + Énergie during the event. The Centre des congrès de Québec owns storage areas near the Exhibition Hall and is solely responsible for the management of these areas. Storage during the convention is mandatory. This service includes the labelling of belongings and the handling associated with storage.

Exhibitors arriving at the loading dock with their equipment may, if they wish, bring their own equipment to their booth, or call on the staff of the Centre des congrès de Québec. A cart will be provided if necessary.

Exhibitors are **not authorized** to store their material themselves. No cardboard boxes or empty shipping crates will be allowed inside or behind the booth. All materials must be labelled (see example in Appendix 1) and handed over to the Centre des congrès de Québec for storage.

IMPORTANT

All materials not collected by the exhibitor's carrier or courier at the end of the exhibition dismantling will automatically be taken in charge by the Centre des congrès de Québec and the exhibitor will be billed for the cost.

EARLY SHIPMENT

For questions about early shipment and storage, please contact Ingrid Metta at Ingrid.Metta@mrnf.gouv.qc.ca or 418 627-6269, extension 705238.

Please note that no materials can be delivered to the Centre des congrès de Québec before Friday, November 13, 2026.

IMPORTANT

Exhibitors using courier services such as FedEx, UPS, DHL or others, must ensure that customs fees, taxes, and other fees are paid in advance. Shipments labelled "to be collected" will not be accepted by the Centre des congrès de Québec or by the organizers of Québec Mines + Énergie.

CANCELLATION

All requests to cancel rental contracts must be received by October 15, 2026. A fee equal to 50% of the total cost of the invoice will be deducted from the refund. No refunds will be issued for cancellations received after this deadline.

OBLIGATIONS AND RESTRICTIONS

Booth Installation

Booths will be set up on Monday, November 16, 2026, between 9:00 a.m. and 7:00 p.m.. You may, however, use the period on Tuesday, November 17, between 7:00 a.m. and 8:30 a.m. to finalize the setup of your booth. No booths may be set up after this time. Exhibitors must remain within the space allotted to them. No overlapping into neighbouring spaces or aisles will be tolerated.

Structure and Dimensions

The height of a booth structure **must not exceed 8 feet** unless the exhibitor has obtained prior authorization from the Organizing Committee

In order not to interfere with another exhibitor, structures, counters, and tables located on the sides must not exceed 8' in height for 4x 10'x10' island booths.

For booths with neighbours on the left and right: structures, counters and tables along the sides must not exceed 4 feet in height, and those on the back wall of the structure must not exceed 8 feet in height (over a maximum depth of 5 feet from the bottom, see image on the right). Curtain dividers may not be used as display surfaces.

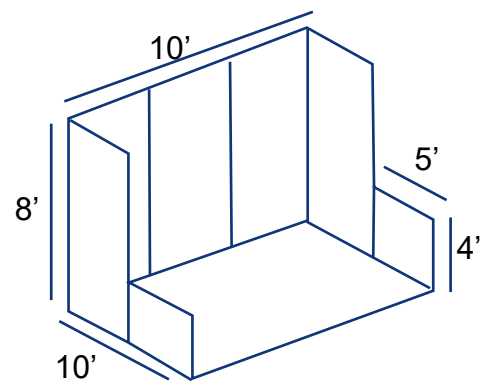

During the Exhibition

Exhibitors can access the Exhibition Hall from 7:00 a.m.. Please note that on Tuesday, customers will have access to the hall as early as 8:30 a.m. to listen to the addresses on the main stage.

The exhibition halls are supervised at all times. However, the Centre des congrès de Québec and the Québec Mines + Énergie organizers are in no way responsible for loss, theft or damage to property, or for injuries sustained by anyone during the event. An Exhibitor Service Desk will be operated by the organizers for the duration of the event.

OBLIGATIONS

The following obligations and restrictions apply to exhibitors and workers involved in installing and dismantling booths.

Insurance

Exhibitors must have their own liability insurance (\$2,000,00 minimum). Québec Mines + Énergie or its agents assume no liability for personal injury. The same applies to material damage to products, booths, equipment, or decorations resulting from fire, water or theft on the rented premises or during transit through the building, regardless of the cause.

Recycling and Residual Materials Collection

Exhibitors must use the bins provided for recycling (paper, cardboard, glass, plastic) both during installation/dismantling and during the exhibition. Other selective collections may be added to those listed above.

Garbage cans must be placed in the aisle in front of the booth each evening, as soon as the Exhibition Hall closes. They will be emptied free of charge by the staff of the Centre des congrès de Québec. Garbage cans left inside the booth will not be emptied.

RESTRICTIONS

Common Areas

Exhibitors must not at any time obstruct hallways, elevators, escalators, entrances, halls, lobbies, signage screens, plasma screens, stairways or emergency exits at the Centre des congrès de Québec.

Animals

The presence of animals must be approved in advance by the Québec Mines + Énergie organizers. Only service dogs for disabilities are permitted without restriction.

Stickers

Stickers of any kind are strictly prohibited by the Centre des congrès de Québec.

Balloons and Confetti

The use of helium balloons must be pre-authorized by the Québec Mines + Énergie organizers. A fee will be charged for retrieving balloons from the ceiling after your activities. The use of confetti and glitter is strictly prohibited.

Alcohol Consumption During Installation and Dismantling

To reduce the risk of accidents, no alcoholic beverages are allowed during the installation and dismantling of booths.

Children

For safety reasons, children are not allowed on the loading dock or in the exhibition hall during installation and dismantling.

Fire and Motor Vehicles

Exhibitors must comply with fire prevention regulations. See the "Fire Safety and Prevention Regulations" document available at: <https://www.convention.qc.ca/en/event-planners/client-guide/>.

Noise Limits

Equipment or devices producing noise or odours that disturb exhibitors or visitors will not be tolerated, and their operation will have to be discontinued. Noise levels must not exceed 70 decibels at a distance of four feet from the source.

Adhesive Tape

The only adhesives allowed at the Centre are listed below (not available on site):

- Walls: Glue Dot® Strips, removable adhesives;
- Floors: Echo Tape CL-W6300 or VI-N6120 or equivalent Double Face Echo Tape DC-W188F;
- Brick walls: Glue Dot® Strips, removable adhesives.

Food Services

Maestro Culinaire has an exclusive partnership with the Centre des congrès de Québec for all food and beverage services. Maestro Culinaire is the exclusive holder and provider of alcoholic products inside the Centre des congrès de Québec. All outside alcohol, even for personal use, is strictly forbidden.

If you wish to distribute or sell food samples in your stand, you must obtain prior authorization from Maestro Culinaire.

Maestro Culinaire

Audrey Théberge

Tél. : 418 647-7711, extension 4613

audrey.theberge@maestroculinaire.ca

Tobacco and E-Cigarettes

The Centre des congrès de Québec offers a smoke-free environment. Since May 31, 2006, in accordance with the provisions of the Law on tobacco, smoking is strictly forbidden inside the Centre des congrès de Québec and on the loading docks, without exception.

LABEL EXAMPLE FOR SHIPPING

Sender's Name: _____
Address : _____ _____
Telephone #: _____
Number of boxes: _____
Carrier: _____
Customs broker's name: _____
COMPANY NAME OF THE EXHIBITOR C/O: Québec Mines + Énergie 2026 Booth #: _____
 Centre des congrès de Québec 855, rue Jean-Jacques-Bertrand Loading Dock, level 4 Québec (Québec) G1R 5V3

